

## **DETECTION OF VOLATILE ORGANIC COMPOUNDS USING TITANIUM DIOXIDE COATED WITH DYE-PORPHYRINS THIN FILMS IN BULK ACOUSTIC SYSTEM**

Syariena Arshad<sup>a</sup>, M. M. Salleh<sup>a</sup> and M. Yahaya<sup>b</sup>

<sup>a</sup>*Institute of Microengineering and Nanoelectronics (IMEN)*

<sup>b</sup>*School of Applied Physics, Faculty of Science and Technology, Universiti Kebangsaan Malaysia, 43600 Bangi, Selangor, Malaysia*

### **ABSTRACT**

Thin films of titanium dioxide (TiO<sub>2</sub>) coated with dye porphyrins were prepared on Quartz Crystal Microbalance (QCM) using sol-gel dip coating method. Two porphyrin dyes, 5,10,15,20-tetraphenyl-21H,23H-porphine manganese (III) chloride and 5,10,15,20-tetraphenyl-21H,23H-porphine iron (III) chloride, were used as sensing materials. Bulk acoustic system has been designed and used to detect some volatile organic compounds (VOCs). The sensing sensitivity of the QCM coated with thin films has been measured with respect to acetone and 2-propanol vapors. It was found that all thin films were sensitive and had selectivity properties towards both vapors.

### **INTRODUCTION**

Volatile organic compounds (VOCs) have been known as major pollutants in environment, release from various industrial activities and combustion of automobile engines. Some of them are carcinogens and cause bad health impact to human and nature. There is an increasing public concern about the presence of environmental pollutants. Thus, the requirement for cheap and reliable sensors is urgent. The most important in developing a gas sensor is that the sensing element of the sensor should have selectivity property. That is the sensor able to differentiate the presence of various kinds of gases [1].

Quartz Crystal Microbalance (QCM) sensors are widely used for determining volatile organic compounds (VOCs) [2]. QCM is a piezoelectric quartz crystal which oscillates at a resonance frequency determined by several factors, including the mass of the crystal. The principle of the sensor is that the QCM frequency will decrease when exposed to the VOC. The decrease in frequency is proportional to the increase in mass due to the presence of gas adsorbed on its surface, according to the Sauerbrey law:

$$\Delta f = -k S_m \Delta m \quad (1)$$

Where  $k$  is geometric factor for the fraction of the active device area being perturbed,  $S_m$  is the device specific constant and  $\Delta m$  is changed in mass/area on the device surface. A QCM sensor can be made selective by coating the surface of quartz crystal with thin film of a particular material. The sensor characteristic depends on the sensing film coated on its electrodes (gold electrodes). Organic compounds have been used by many researchers as sensing element because of their high sensitivity, good recoverability and selectivity. Nanoparticles titanium dioxide (TiO<sub>2</sub>) coated with dye-porphyrins thin films

are a promising candidate for the sensing film. Nanostructure thin film gives larger surface area and provides high sensitivity at low gas concentrations [3]. The sensing properties will enhance with the decreasing grain size of the material [4].

The purpose of the work was to prepare the gas sensor by means of the widely used sol-gel technology and to investigate the sensor sensitivity when covered with TiO<sub>2</sub> coated with dye porphyrin thin film. The metalloporphyrin compounds used were 5,10,15,20-Tetraphenyl-21H,23H-porphine manganese (III) chloride, MnTPPCL and 5,10,15,20-Tetraphenyl-21H,23H-porphine iron (III) chloride, ITPPCL. The sensitivity of the thin films to different types of VOC like acetone and 2-propanol vapors is reported.

## METHODOLOGY

The TiO<sub>2</sub> sol was prepared by using titanium (IV) ethoxide, TEOT (obtained from Aldrich), kalium chloride, KCl and ethanol (received from MERCK). Firstly, KCl powder was dissolve in deionized water and added into ethanol with stirring. Then TEOT was dropped wisely into the solution under nitrogen in a glove box. Acetylacetone (supplied by MERCK) as stabilizer was added into the solution and was stirred for 2 hours at room temperature. Nanoparticles TiO<sub>2</sub> sol were successfully prepared. To the TiO<sub>2</sub> sol, Poly-L-Lysine, PLL (molecular weight =70,000 and supplied by Aldrich) was added drop wise and keeps stirring to charge the TiO<sub>2</sub> nanoparticles into positive charge. Separately, 0.2 mg/ml metalloporphyrin solution was prepared and was added drop wise into the TiO<sub>2</sub> solution. Both solutions were stirred for several hours to obtain a complete mixture of porphyrin and TiO<sub>2</sub> nanoparticles. The volume ratio of porphyrin to TiO<sub>2</sub> was 2.

The QCM substrate used was 10 MHz AT-cut quartz crystal (13.5mm in diameter) with gold electrodes (5 mm in diameter) on each side obtained from ICM manufacturing. The thin film was deposited onto QCM substrate using sol-gel dip coating method. The substrate were dipped in TiO<sub>2</sub> coated dye porphyrin solution for 30 minutes and pulled out with slow and uniform pulling rate of 40 mm/min. A thin and uniform film of TiO<sub>2</sub> coated with dye porphyrin was formed on the substrate and dried with nitrogen at room temperature. Surface analysis was conducted with scanning electron microscopy (SEM) and atomic force microscopy (AFM).

Figure 1 shows an experimental set-up for the bulk acoustic sensor system. The QCM coated with thin film was positioned in the sensor chamber. A power voltage of 4.5 V was supplied to the oscillator circuit. Nitrogen gas was purge into the sensor chamber for 30 minutes to remove the air out of the chamber. The detection of VOCs; 2-propanol and acetone were started by exposing the thin film to the vapor with the flow rate of 10 ml/min. The gas flow rate was controlled by mass flow controller (MFC). The sensitivity of the thin films to the VOCs were studied by measuring the QCM frequency changes using FC-7015U universal frequency counter and the data were transferred to the computer. The recovery time was recorded starting from when the VOC vapor is cut off and pure nitrogen is purge into the system.

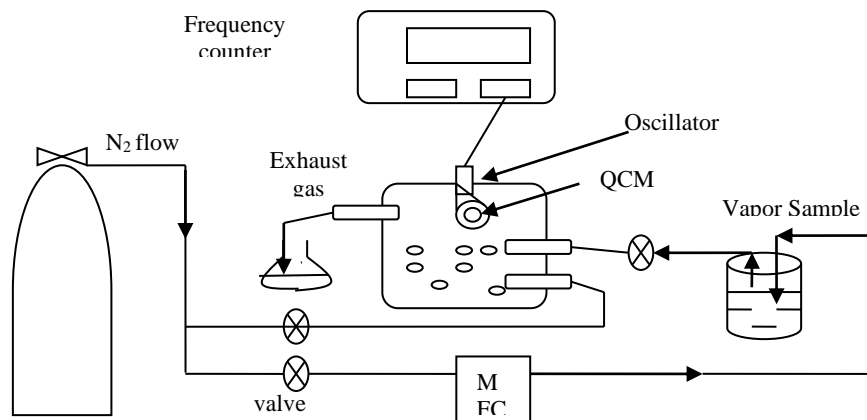
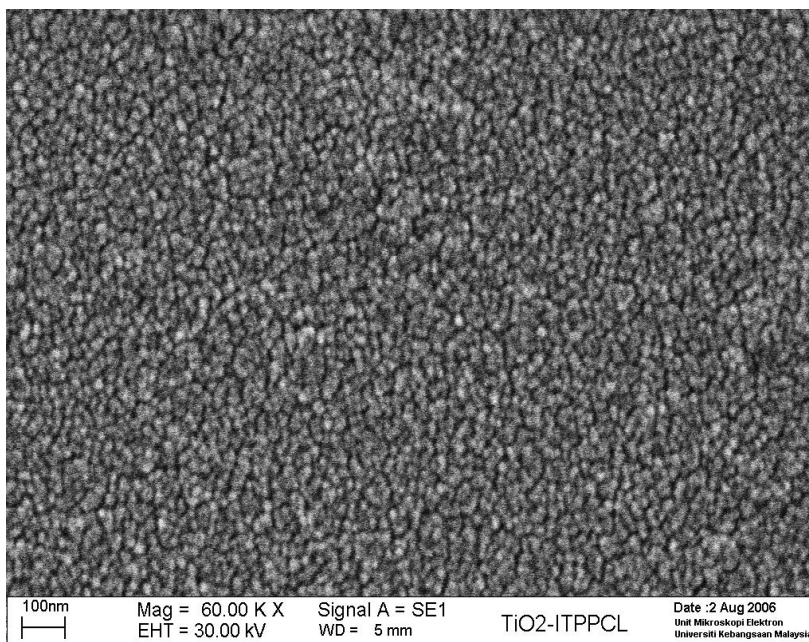

Figure 1: The bulk acoustic system set-up

## RESULTS AND DISCUSSION

Figure 2 shows the SEM images of ITPPCL and MnTPPCL thin films. The nanostructure thin film was obtained with the average grain size of 15.4 nm for ITPPCL thin film and 16.2 nm for MnTPPCL thin film. It was expected that the nanoscale grain size particle provides larger surface area for the VOC molecules to adsorb and enhance the sensing properties.



(a)

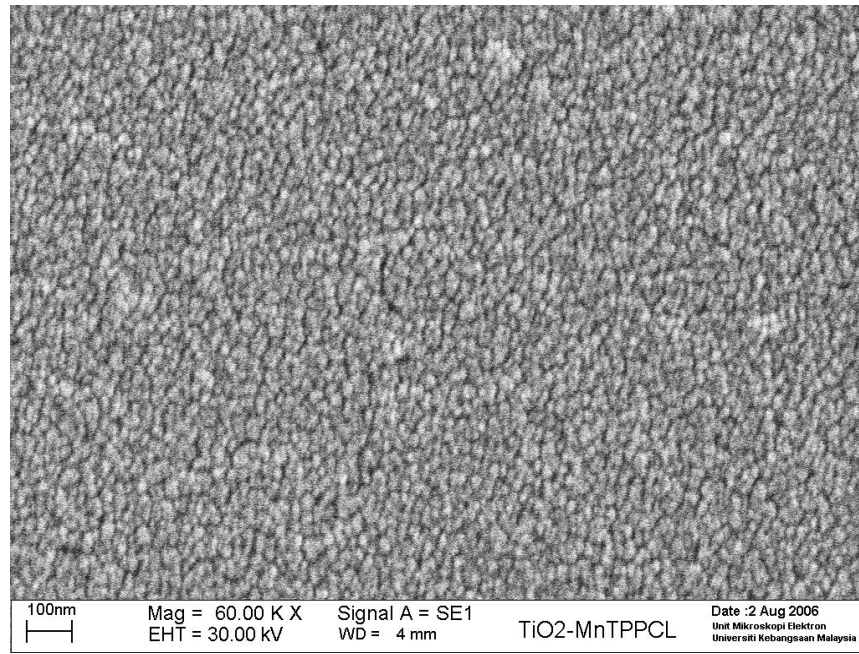

(b)

Figure 2: SEM image of (a) ITPPCl and (b) MnTPPCL thin film

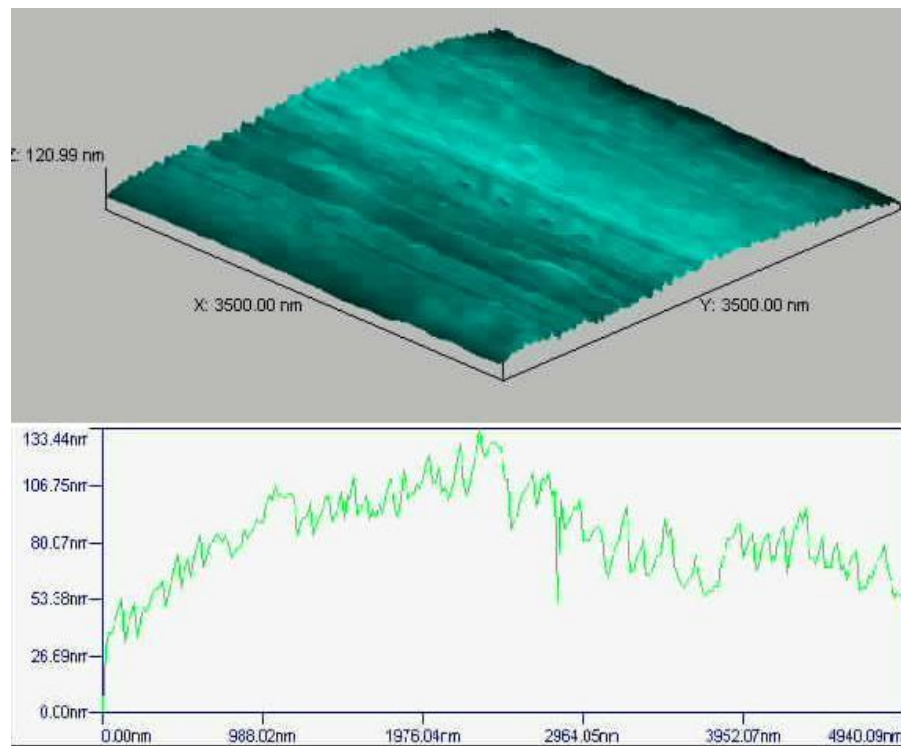

(a)

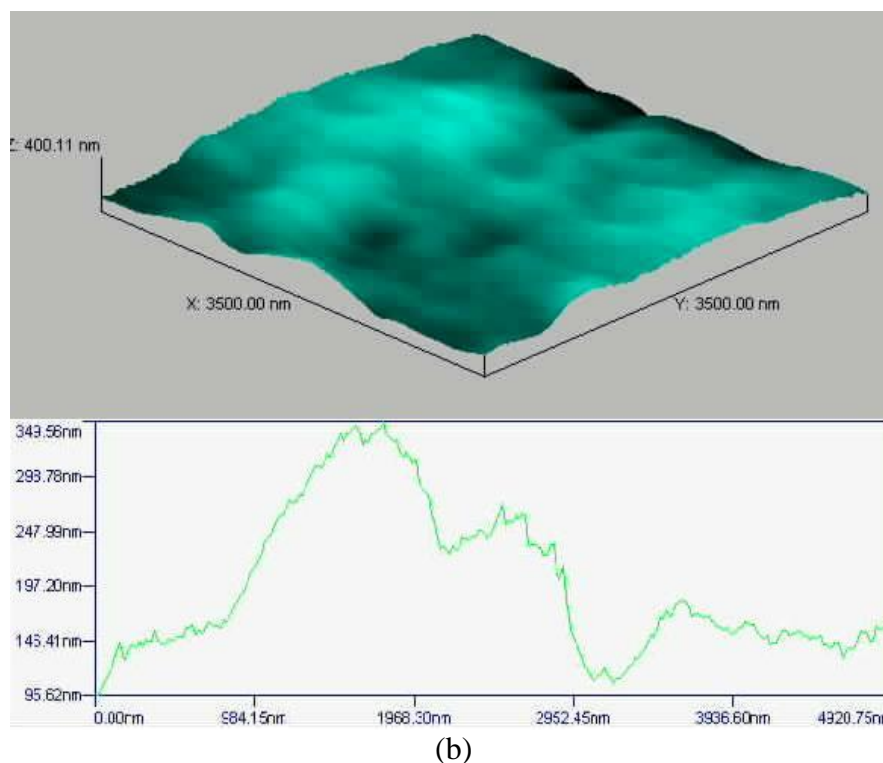

Figure 3: AFM image of (a) ITPPCl and (b) MnTPPCl thin films

Figure 3 illustrates a three dimensional image of ITPPCl and MnTPPCl thin films. The surface analysis of the image revealed that the roughness of ITPPCl thin film was 16.06 nm and MnTPPCl thin film was 54.96 nm. The ITPPCl thin film has a smooth surface with the presence of small hills at the centre of the film while MnTPPCl thin film surface shows the present of many hills and valleys. The present of hills and valleys on the MnTPPCl thin film surface provide a larger adsorption sites and higher chance to adsorb vapor molecules.

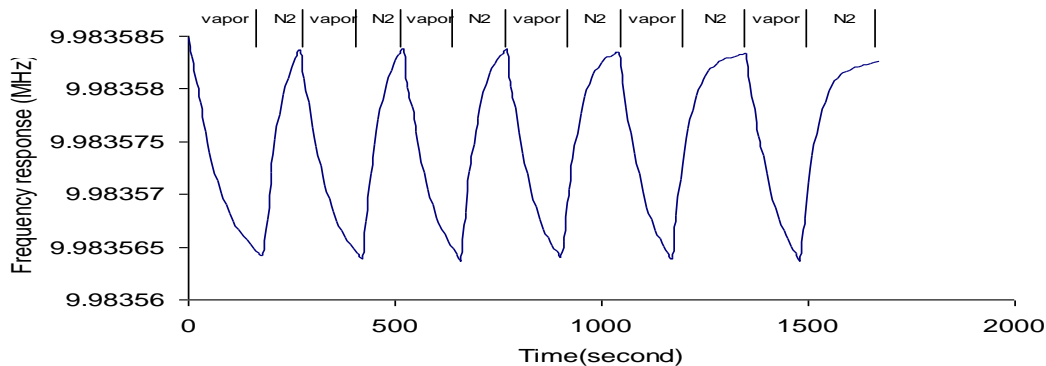

Figure 4: Response of ITPPCl thin film towards acetone vapor

Figure 4 shows the response of ITPPCL thin film towards acetone vapor. When the thin film was exposed to the vapor, the frequency response was decreasing. It reduces 195 Hz frequency shift for 180 seconds exposure. It was found that ITPPCL thin film has good recoverability and reversibility when the thin film was exposed to the vapor up to six cycles. The average recovery time after the vapor was removed from the system was within 135 seconds. It was observed that the recovery time was increase with the increasing number of cycle. Then the same thin film was exposed to 2-propanol vapor and the frequency was decrease for 152 Hz. The recovery time was within 98 seconds. The same method was repeated for MnTPPCL thin film. Upon exposure to acetone, the frequency of MnTPPCL thin film decreased to 218 Hz and the recovery time was 222 seconds. While exposure to 2-propanol vapor produces 197 Hz frequency shifts with the recovery time of 117 seconds. The presence of hills and valley on the surface of the thin film as shows in figure 3(b) cause the vapor molecules were trapped into the valley and were hard to release from the film surface. For the film with rough surface structure, the availability of the adsorption sites on the surface may be high but the vapor molecules were not easily sweep away from the surface. Hence its recovery time may increases.

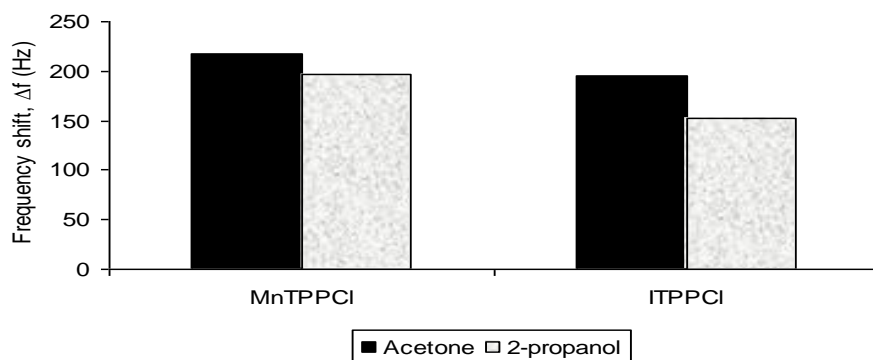

Figure 5: The variation response for acetone and 2-propanol vapors towards MnTPPCL and ITPPCL thin films

Figure 5 shows the variation response for acetone and 2-propanol vapors towards MnTPPCL and ITPPCL thin films. The different in patterns indicated that both thin films have selectivity property. According to equation (1), the frequency change depends on increasing of mass due to the presence of gas adsorbed on the film surface. Vapor with high molecular weight had higher chances to adsorb to the rough film surface. Meanwhile, vapor with low molecular weight had more chances to adsorb to the smooth film surface. The MnTPPCL thin film with high roughness surface demonstrated higher response towards 2-propanol (molecular weight of 60) compare with ITPPCL thin film. But in this case, MnTPPCL thin film also demonstrated higher response towards acetone vapor (molecular weight of 58.1). This may due to strong interaction of vapor with MnTPPCL thin film.

## CONCLUSION

The sensing sensitivity of the titanium dioxide coated with dye-porphyrins thin films towards acetone and 2-propanol vapors have been investigated. Both MnTPPCL and ITPPCL thin films showed good recoverability, reversibility and selectivity with MnTPPCL thin film showed higher frequency response towards both vapor compared to ITPPCL thin film. However the recovery time was longer for MnTPPCL thin film towards both vapors due to its high roughness surface compare with ITPPCL.

## ACKNOWLEDGEMENT

This project was supported by the Ministry of Science, Technology and Innovation (IRPA project no. 03-02-02-0020-SR003/07-06).

## REFERENCES

- [1] Mohamed, R., Salleh, M.M., Yahaya, M.B. (2003); *NSM Proceeding 2003*, Perlis, p. 52.
- [2] Arshad, S., Salleh, M.M., Yahaya, M.B. (2005); *NSM Proceeding 2005*, Kuching, November 2005, p. 318.
- [3] Carotta, M.C., Ferroni, M., Gnani, D., Guidi, V., Merli, M., Martinelli, G., Casale, M.C., Notaro, M. (2000); *Sensor Actuators B*, **58**, p. 310.
- [4] Yamazoe, N., Miura N. (1992); *Chemical Sensor Technology*, Vol 4 (Elsevier, Amsterdam).
- [5] Kikuchi, M., Shiratori, S. (2005); *Sensor and Actuators B*, **108**, p. 564.
- [6] Salleh M.M., Umar A.A., Yahaya M.B. (2003); *Proceedings of SPIE 2003*, Australia, December 2003, p. 107.
- [7] Montmeat, P., Madonia, S., Pasquinet, E., Hairault, L., Gros, C.P., Barbe, J.M., Guillard, R. (2005); *IEEE Sensors Journal*, **5**(4).